



AAON

RN-A000-KD/FW-108-14,18,24,36-DR
 A Box (6 - 10 Ton)
 w/ Heat Wheels & Duct Rails

8737 AL Hwy 51
 Opelika, AL 36804
 Ph: (334)826-9538
 Fax: (334)826-9539

Project Name: _____

Delivery Zip Code: _____

Standard Features

- Knock Down or Welded 18ga G90 galvanized steel construction
- 14, 18, 24 or 36 inches high
- Factory installed PT 1x4 wood nailer
- Supplied 1-1/2x1/4" closed cell neoprene gasket

Options (please check):

- Heavier gauge metal
- 5052-H32 AL or 304 SS construction
- Custom height
- Slope
- Horizontal duct connections
- Turning vane
- 1" or 2" isolation rails
- Seismic rating/stamped
- Filtration
- Metal Building construction
- 1"x1.5# density insulation
- Other per customer specs

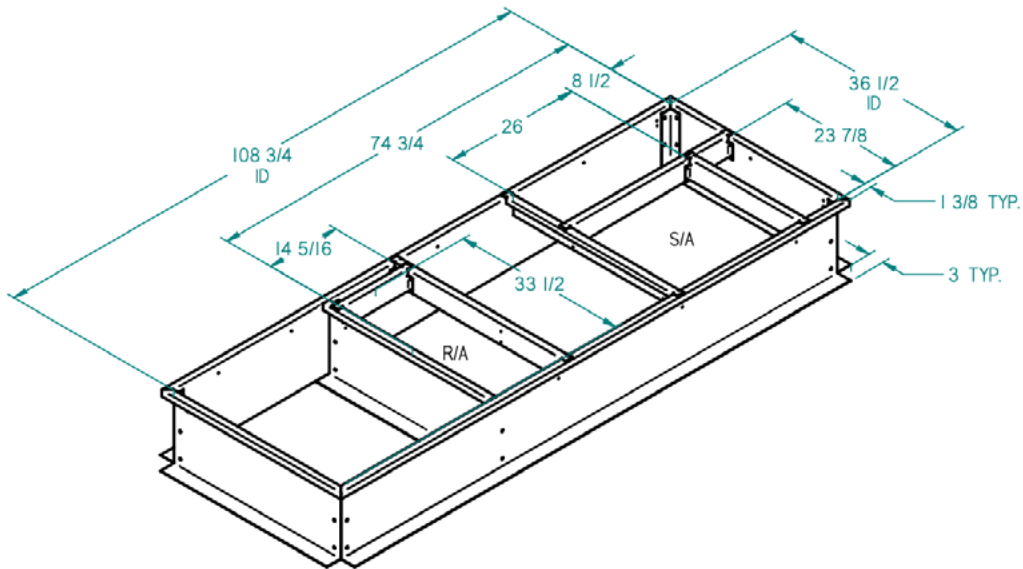

Quantity	KD/FW	Height	Options	Special Notes